

**DESCRIPTION**

The ASI6416 is a professional PCI audio adapter designed for use in the broadcast and entertainment markets.

Using Cirrus Logic's CobraNet technology for streaming audio over Ethernet, the ASI6416 provides 8 stereo inputs and outputs. It can be connected to any CobraNet compliant device.

The ASI6416 is based on the TMS320C6713 VLIW floating point DSP connected to a high speed bus-master PCI interface.

AudioScience MRX technology allows up to 16 streams of different formats and sample rates to be played, recorded and mixed over CobraNet. A choice of 16bit PCM, MP3 or MPEG layer 2 compression is available on all streams.

AudioScience provides ASIRoute, an application that allows CobraNet routing connections to be setup between the ASI2416 and any other compliant CobraNet device on the network. Alternatively 3<sup>rd</sup> party CobraNet design and management software may be used such as CobraCAD from Cirrus Logic or CobraNet Manager from D&R Electronica B.V.

**FEATURES**

- 8 stereo 24bit CobraNet inputs and outputs on 100Mbit Ethernet operating at 48kHz or 96kHz.
- 8 stereo streams of MP3, MPEG Layer2 or PCM playback
- 8 stereo streams of MP3, MPEG Layer2 or PCM record.
- MRX™ technology supports recording, playing and mixing of multiple stream formats and sample rates.
- TSX™ time scaling allows compression/expansion of play streams by up to +/-20% with no pitch shift.
- Low Profile PCI card allows use in 2U high rackmount computers.
- Up to 4 cards in one system.
- Windows 2000/XP and Linux software drivers available.

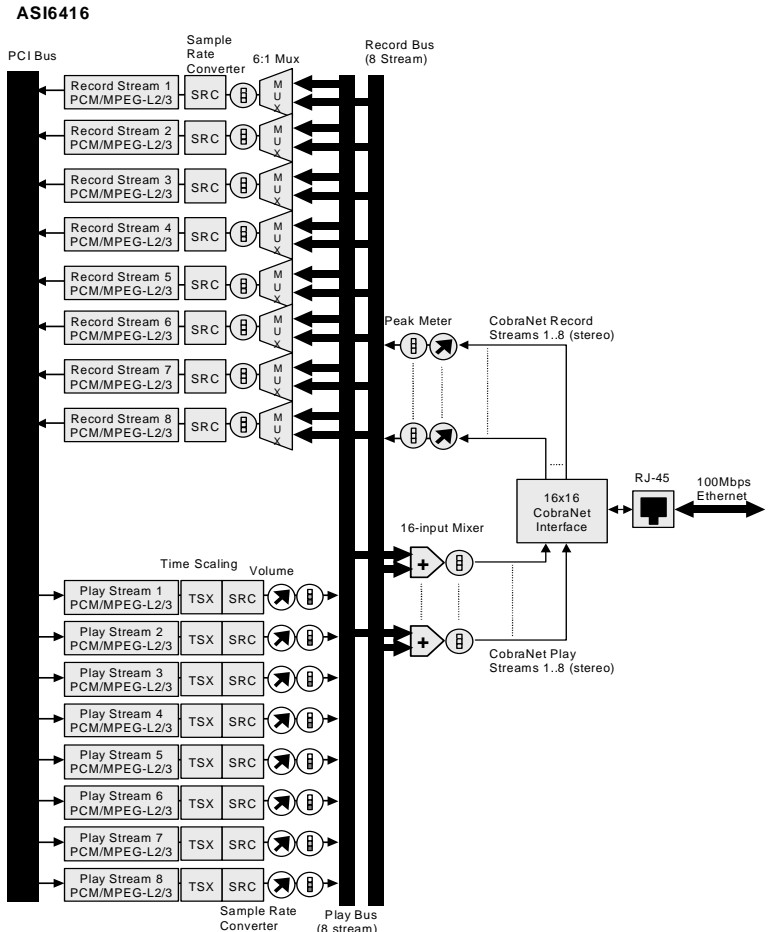

# 1. SPECIFICATIONS

## COBRANET INPUT/OUTPUT

Type	100BaseT Ethernet
Connector	RJ-45
Precision	16, 20 or 24bit PCM
Sample Rate	48 or 96kHz (when operating at 96kHz the number of channels is reduced from 16 to 8)
Latency	1.33, 2.66 or 5.33ms
Control Protocol	SNMP

## SIGNAL PROCESSING

DSP	Texas Instruments TMS320C6713@300MHz
Memory	8MB
Audio Formats	8 bit unsigned PCM 16 bit signed PCM 32 bit floating point PCM MPEG-1 Layer 2 MPEG-1 Layer 3(MP3) (MPEG Layer-3 audio coding technology licensed from Fraunhofer IIS and THOMSON multimedia)

## GENERAL

Bus	Universal 32bit PCI (3.3V or 5V signaling)
Dimensions	PCI form factor – 5.25" x 3.25" x 0.5" (133mm x 82mm x 13mm)
Weight	8 oz (227g) max
Operating Temperature	0C to 70C
Power Requirements	+3V@1.5A, +5V @ 100mA

# 2. ADAPTER MODES

The ASI6416 supports several adapter modes. The mode setting is saved on the adapter's EEPROM and will be restored after reboot.

The Mode setting is selected using the Mode control dropdown box located on the Line Out 1 panel of ASIMixer. A restart is required after selecting a new mode:

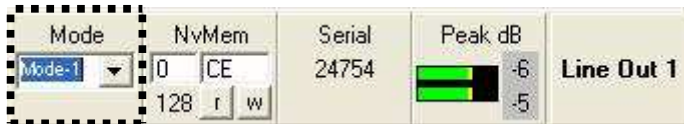

### Mode 1 (default) – Standard Mixing

This mode supports 8 Play streams and 8 Record streams with full mixing capabilities.

### Mode 2 – Minimal Mixing

This mode supports playback from each Play device to a single LineOut and has no LineIn to LineOut mixing capabilities. This conserves DSP MIPS. Mode 2 supports recording stereo MP2 at 48 kHz on all 8 Record streams.

### 16-Play

This mode supports 16 Play streams and 16 Record streams. It is recommended that play and record formats be constrained to 48 kHz mono PCM if all 16 devices are to be used.

The 16-Play mode supports mapping a single Play device to a mono CobraNet channel, allowing independent audio output on each channel.

The mixer layout is changed slightly for 16-Play mode. Instead of any Play being mixed to any line out, pairs of plays are mixed to a single line out. For example, Plays 1&2 are mixed to line out 1, Plays 3&4 to line out 2, etc. Additionally, to direct Play 1 to the left output channel only, use the Channel Mode control and select "StoL". Similarly,

to direct Play 2 to the right output channel only, use the Channel Mode control and select "StoR". These selections can be made using either ASIMixer or ASIControl.

**Multichannel**

Not implemented yet.

**3. APPLICATIONS**

The ASI6416, along with other AudioScience and 3<sup>rd</sup> party CobraNet products can be used to create a fully networked radio station where both data and audio are carried on the station's Ethernet LAN.

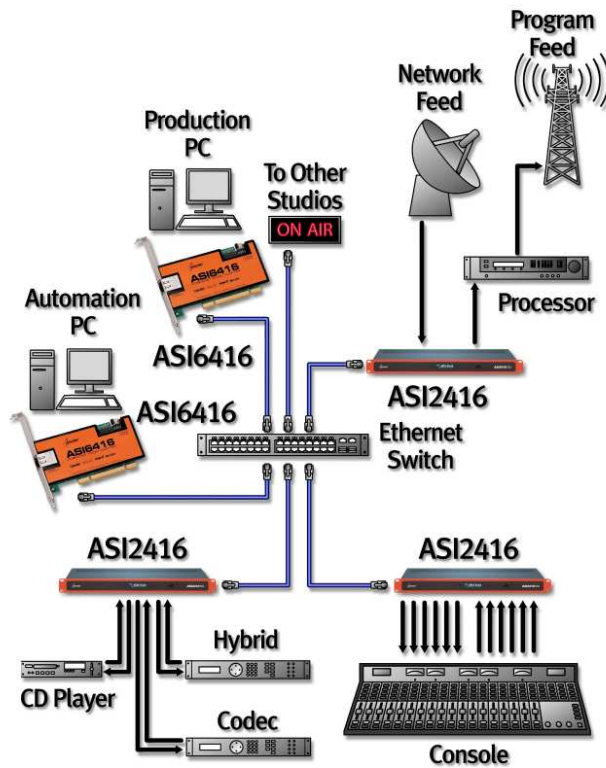

[end]