

1 DESCRIPTION

The ASI5001 and ASI5002 are professional PCI audio adapters designed for use in the broadcast and entertainment markets.

The ASI5001 features four balanced analog stereo inputs and one balanced analog output.

The ASI5002 features four AES/EBU inputs and one AES/EBU output, and four balanced analog stereo inputs and one balanced analog output.



2 FEATURES

- One stereo stream of PCM playback to one stereo output
- Eight stereo streams of PCM record
- Four balanced stereo analog inputs
- Four transformer coupled AES/EBU digital inputs (ASI5002 only)
- 24bit analog-to-digital and digital-to-analog converters, 100dB SNR and 0.002% THD+N
- Formats include 8, 16, and 32bit PCM
- Sample rates of 32, 44.1, 48, 64, 88.2, 96, and 192kHz
- Syncs to any AES/EBU input (ASI5002 only)
- Up to 4 cards in one system
- Windows 7, XP, Server 2003, Server 2008, and Linux software drivers available

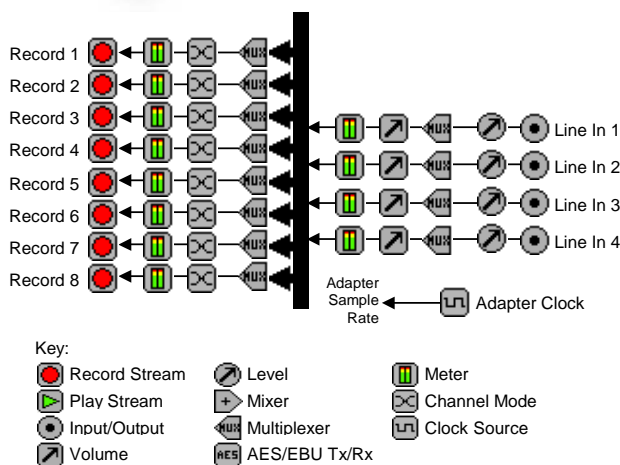

Key:

Record Stream	Play Stream	Meter
Input/Output	Mixer	Channel Mode
Volume	Multiplexer	Clock Source
	AES/EBU Tx/Rx	

ASI5002

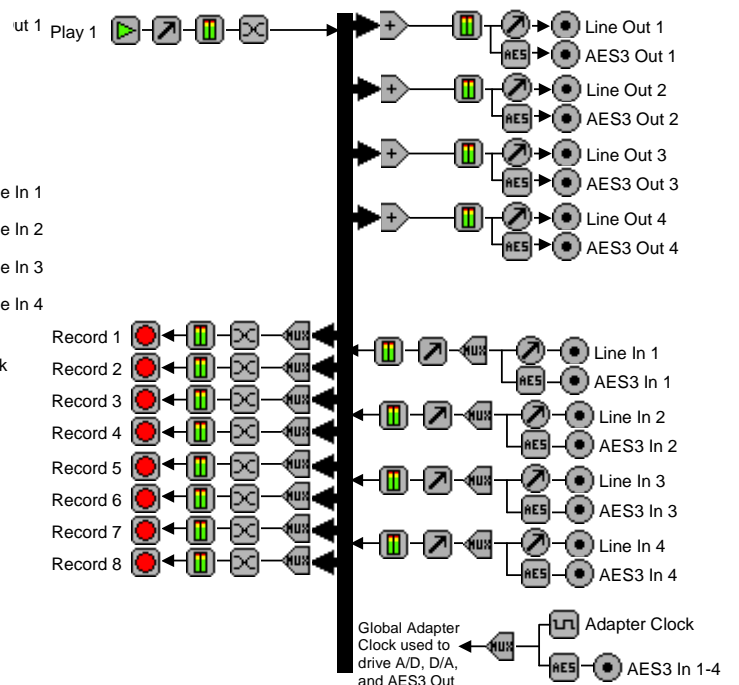

3 SPECIFICATIONS

ANALOG INPUT/OUTPUT

Type	Balanced
Connector	Mini50(SCSI-II type)
Input Level	-10 to +20dBu in 1dBu steps
Input Impedance	20K ohms
A/D converter	24bit Over sampling
Output Level	-10 to +20dBu in 1dBu steps
D/A converter	24bit Over sampling
Load Impedance	600ohms or greater
S/N Ratio [1]	>105dB (record or play)
THD+N [2]	<0.0015% (record or play)
Sample Rates	32, 44.1, 48, 64, 88.2, 96 and 192kHz
Frequency Response	20Hz to 20kHz +/-0.25dB, 20Hz to 50kHz +0.25/-3dB

DIGITAL INPUT/OUTPUT

Type	AES/EBU (EIAJ CP-340 Type I / IEC-958 Professional)
Connector	Mini26(SCSI-II type)
Sample Rates	32, 44.1, 48, 64, 88.2, 96 and 192kHz.

NOTE: All inputs must be synchronized.

SAMPLE RATE CLOCK

Internal	32, 44.1, 48, 64, 88.2, 96 and 192kHz NOTE: When playing and/or recording multiple files, one sample rate must be used.
External	Synchronizes to AES/EBU digital input #1. NOTE: All AES/EBU inputs must be synchronized to a common clock as the ASI5000 does not have sample rate converters.

SIGNAL PROCESSING

DSP	Texas Instruments TMS320C6205@190MHz
Memory	8MB
Audio Formats	8 bit unsigned PCM 16bit signed PCM 24bit signed PCM 32bit signed PCM

BREAKOUT CABLES (included)

Analog	CBL1004: Mini 50 to Centronics 50 adapter CBL1044: Centronics 50 to 8 in and 8 out XLR
Digital	CBL1101: Mini 26 to Centronics 50 adapter CBL1144: Centronics 50 to 4 in, 4 out XLR

GENERAL

Bus	Universal 32bit PCI (3.3V or 5V signaling)
Dimensions	PCI form factor – 6.5" x 3.9" x 0.6" (165mm x 100mm x 15mm)
Weight	8 oz (227g) max
Operating Temperature	0C to 70C
Power Requirements	+3.3V@500mA, +12V @ 300mA, -12V @ 130mA (NOTE 3.3V must be available from the PCI bus)

[2] - THD+N measured using a +20dBu 1kHz sine wave sampled at 48kHz, 20-20kHz b/w and A weighting filter

[1] - S/N Ratio is the difference between a 1kHz +20dBu sine wave and digital zero using an A weighting filter and 20-20kHz b/w

4 REVISIONS

Date	Description
08 June 2009	Updated block diagrams. Added Multichannel information; Section 8.4. Added more information throughout Section 8. Updated format of datasheet.
16 September 2010	Features: updated drivers available. Added TOC.

5 CONTENTS

1	DESCRIPTION	1
2	FEATURES.....	1
3	SPECIFICATIONS.....	2
4	REVISIONS.....	3
5	CONTENTS	4
6	CONNECTORS	5
6.1	ANALOG – MINI 50PIN.....	5
6.2	DIGITAL – MINI 26PIN	5
7	CABLES (INCLUDED)	5
7.1	ANALOG.....	5
7.2	DIGITAL.....	5
8	MIXER MAP.....	6
9	AUDIO FORMATS.....	7
10	ADAPTER MODES	7
10.1	ADAPTER MODE-1 (DEFAULT) – STANDARD SAMPLE RATE	7
10.2	ADAPTER MODE-2 – HIGH SAMPLE RATE (ANALOG & DIGITAL)	7
10.3	ADAPTER MODE-3 – HIGH SAMPLE RATE (DIGITAL ONLY).....	7
10.4	ADAPTER MODE SSX MULTICHANNEL	8
11	BALANCED ANALOG I/O	8
11.1	ANALOG I/O LEVEL	8
12	AESEBU I/O	9
12.1	CHANNEL STATUS AND USER DATA.....	9
13	SAMPLE RATE CLOCK	9

6 CONNECTORS

6.1 Analog – Mini 50pin

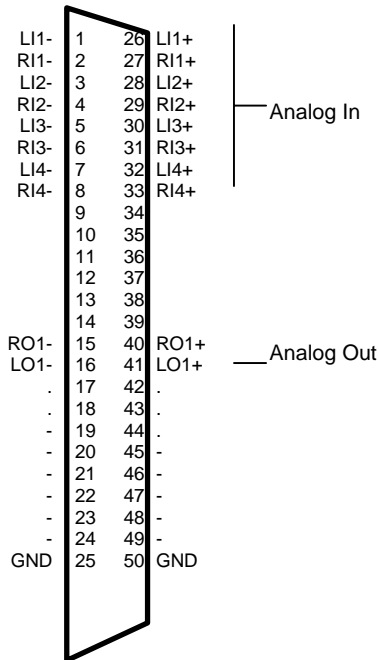

6.2 Digital – Mini 26pin

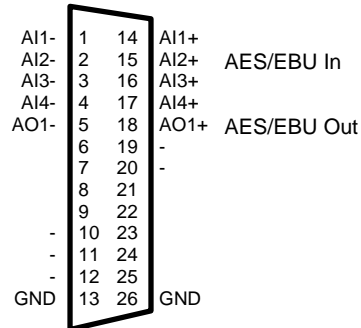

7 CABLES (Included)

7.1 Analog

CBL1004: Mini 50 to Centronics 50 adapter

CBL1044: Centronics 50 to 8 in and 8 out XLR

7.2 Digital

CBL1101: Mini 26 to Centronics 50 adapter

CBL1144: Centronics 50 to 4 in, 4 out XLR

8 MIXER MAP

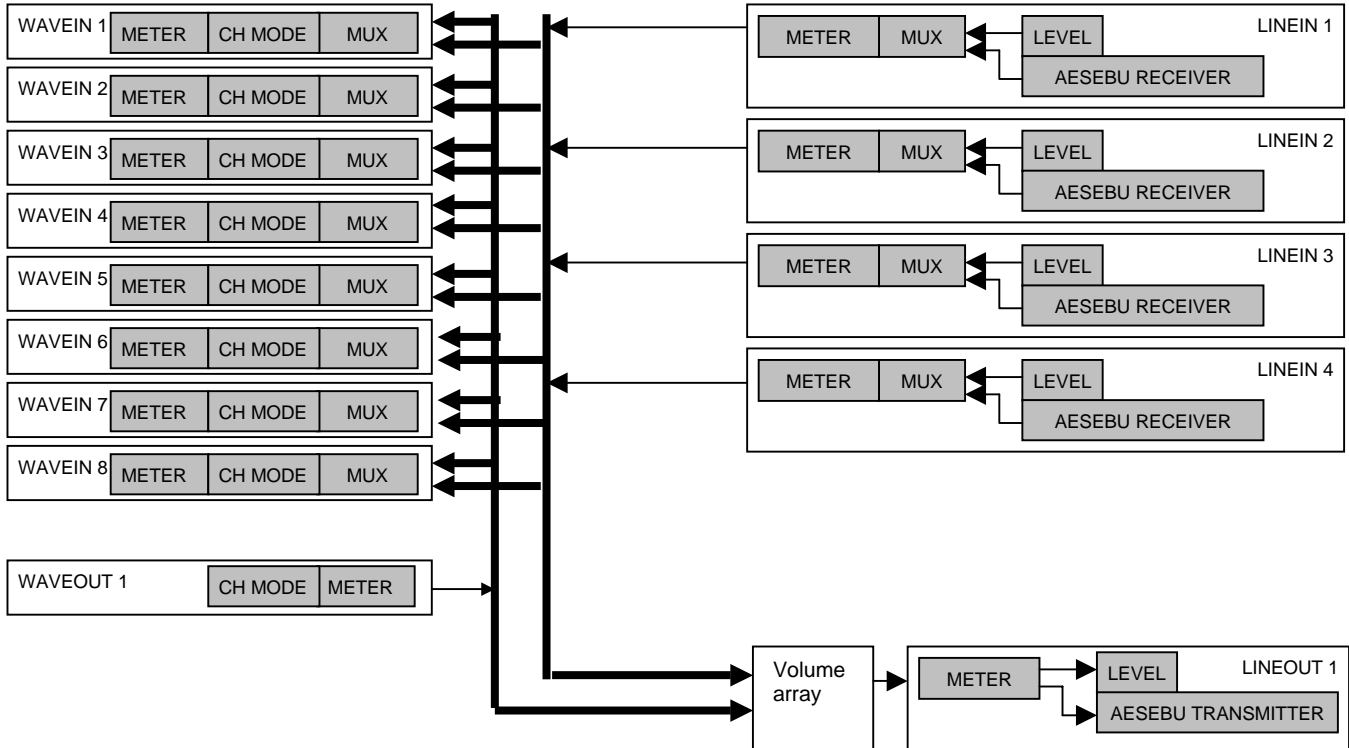

9 AUDIO FORMATS

The ASI500x supports record and play of the following formats:

Format	HPI format	Windows format
8 bit unsigned PCM	HPI_FORMAT_PCM8_UNSIGNED	WAVE_FORMAT_PCM, wBitsPerSample=8
16 bit signed PCM	HPI_FORMAT_PCM16_SIGNED	WAVE_FORMAT_PCM, wBitsPerSample=16
32 bit signed PCM	HPI_FORMAT_PCM32_SIGNED	WAVE_FORMAT_PCM, wBitsPerSample=32
32 bit floating point PCM (+/-1.0)	HPI_FORMAT_PCM32_FLOAT	WAVE_FORMAT_IEEE_FLOAT

10 ADAPTER MODES

The ASI500x supports sample rates up to 192 kHz, but not all rates are available in all modes, or at full sample resolution. The following tables describe the bit resolutions available at various sample rates on an ASI500x. Change the mode setting using ASIControl; a restart of the PC is required. The mode setting is saved on the adapter EEPROM.

10.1 Adapter Mode-1 (default) – Standard Sample Rate

ASI5001 and ASI5002: This mode supports 1 Play stream and 8 Record Streams. 24-bit sampling is supported up to 48 kHz.

Formats supported: PCM8, PCM16, PCM24, PCM32, FLOAT32

Sample Rate (kHz)	Analog sample resolution	AES/EBU sample resolution
32-48	24	24
64-96	Not supported	Not supported
192	Not supported	Not supported

10.2 Adapter Mode-2 – High Sample Rate (Analog & Digital)

ASI5001 and ASI5002: This mode supports 1 Play streams and 8 Record Streams. All sample rates are supported. At sample rates higher than 48 kHz, 16-bit sample resolution is used.

Formats supported: PCM8, PCM16, PCM24, PCM32

Sample Rate (kHz)	Analog sample resolution	AES/EBU sample resolution
32-48	24	24
64-96	16	16
192	16	16

10.3 Adapter Mode-3 – High Sample Rate (Digital Only)

ASI5002 only: This mode supports 1 Play streams and 8 Record Streams. All sample rates are supported at 24 bits resolution. Analog I/O will not work at rates higher than 48 kHz.

Formats supported: PCM8, PCM16, PCM24, PCM32

Sample Rate (kHz)	Analog sample resolution	AES/EBU sample resolution
32-48	24	24
64-96	Not supported	24
192	Not supported	24

10.4 Adapter Mode SSX Multichannel

NOTE: Driver 3.12.03 or higher is required.

ASI5001 and ASI5002: This mode supports 1 Record Stream. 24-bit sampling is supported up to 48 kHz. For more information, see the SSX specification - <http://www.audioscience.com/internet/tech/ssx.htm>. There is no Play Stream in Multichannel mode on the ASI5001/5002.

Formats supported: PCM8, PCM16, PCM24, PCM32

Sample Rate (kHz)	Analog sample resolution	AES/EBU sample resolution
32-48	24	24
64-96	Not supported	Not supported
96-192	Not supported	Not supported

11 BALANCED ANALOG I/O

The ASI5001/5002 has stereo-balanced analog inputs and outputs on a mini 50-pin female connector.

11.1 Analog I/O Level

The analog Level (or Trim) is software programmable independently for the input and output. It can be set from -10 to +20dBu in 1dB increments.

User

Analog levels are adjusted using the Trim/Level controls located on the LineIn and LineOut panels in the ASI Mixer:

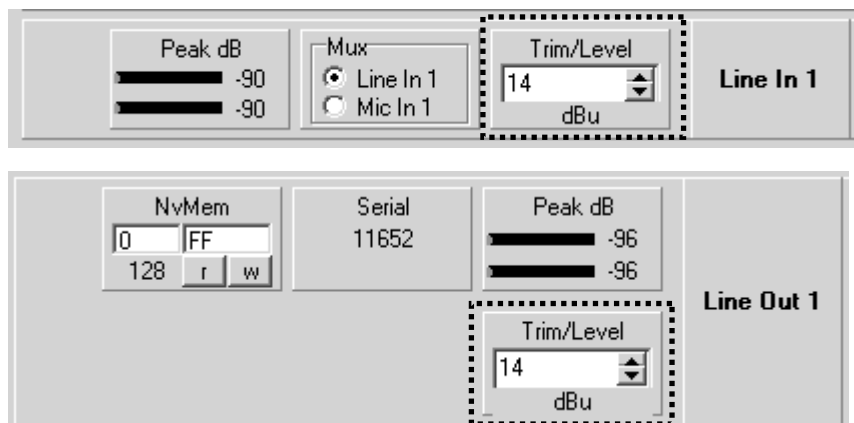

Developer

Windows – Analog levels are controlled using mixerSetControlDetails() on a control of type signed and with the name Level/Trim.

HPI – Analog levels controlled using the HPI_LevelSet() API.

12 AESEBU I/O

The ASI5002 has an AES/EBU digital audio input and output on a mini 26-pin female connector. The AES/EBU I/O operates at 32, 44.1, 48, 64, 88.2, 96 or 192 kHz. The bitstream contains samples of 24bit precision (depending on the samplerate and adapter mode – see section 5). When a valid AES/EBU source is connected to the ASI500x, the card will automatically generate the sample clock from that source.

12.1 Channel Status and User Data

The ASI Mixer does not setup the Channel Status and User Data in the AES/EBU output. This must be done by the application using the following APIs:

Windows – Use Digital I/O controls – see the “AudioScience WavX Specification” (SPCWAVX.PDF)

HPI – Use HPI_AESEBU_Transmitter_SetChannelStatus() and HPI_AESEBU_Transmitter_SetUserData() APIs

Your application can also read the Channel Status and User Data of the AES/EBU input using the following APIs:

Windows – Use Digital I/O controls – see the “AudioScience WavX Specification” (SPCWAVX.PDF)

HPI – Use HPI_AESEBU_Receiver_GetChannelStatus() and HPI_AESEBU_Receiver_GetUserData() APIs

13 SAMPLE RATE CLOCK

The ASI5002 has two methods of generating the sample clock. The default method is to use the on board sample rate generator. The other method is to use the clock derived from any of the AES/EBU inputs. Selection between these two clocking options is automatic. In other words, if a valid AES/EBU data stream is connected to any of the AES/EBU inputs, that input will effectively become the master clock source for the adapter.

Because the ASI5002 captures exact digital samples without any sample rate conversion on the input audio data, all AES/EBU inputs should be locked to the same master clock.

<end>