

### DESCRIPTION

The ASI6244 is a professional PCI audio adapter designed for use in the broadcast and entertainment markets.

It is based on the TMS320C6711 VLIW floating point DSP, which runs at 150MHz and offers a peak of 900MFLOPs.

Both balanced analog and AES/EBU I/O is provided as standard. The AES/EBU may be configured as S/PDIF under software control.

MRX technology allows multiple streams of different format and sample rate to be digitally mixed.

A choice of 16bit PCM, MP3 or MPEG layer 2 compression is available on all streams. A multi-rate digital mixer allows streams of different sample-rates and formats to be mixed together and sent to both analog and digital AES/EBU outputs

Synchronization capabilities include an AES/EBU sync input and Word clock input and output.

### FEATURES

- Four stereo streams of MP3, MPEG Layer2 or PCM playback into four stereo outputs
- Four stereo streams of MP3, MPEG Layer2 or PCM record.
- MRX™ technology supports digital mixing of multiple stream formats and sample rates.
- TSX™ time scaling allows compression/expansion of play streams by up to +/-20% with no pitch shift.
- Four stereo balanced analog and digital play outputs. Four balanced stereo analog and digital inputs.
- 24bit analog-to-digital and digital-to-analog converters - 100dB SNR and 0.002% THD+N
- AES/EBU and S/PDIF digital audio input and output (software selectable) with sample rate converters on all inputs.
- AESEBU and Word clock Sync input allows adapter clock and AES/EBU outputs to be synchronized to external references
- SoundGuard™ transient voltage suppression protects against lightning and other high voltage surges on all I/O
- Up to 8 cards in one system.
- Windows 98/NT/2000/XP and Linux software drivers available.

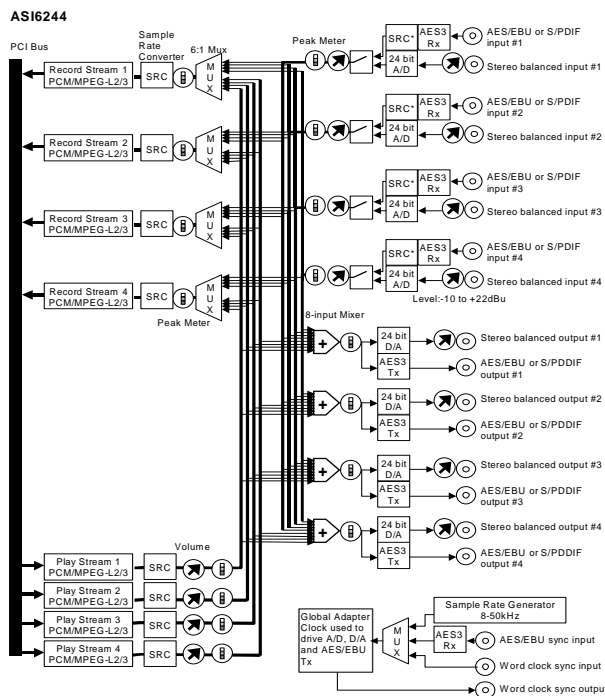

# 1. SPECIFICATIONS

## ANALOG INPUT/OUTPUT

Type	Balanced
Connector	Mini50(SCSI-II type)
Input Level	-10 to +22dBu in 0.5dBu steps
Input Impedance	20K ohms
A/D converter	24bit Over sampling
Output Level	-10 to +22dBu in 0.5dBu steps
D/A converter	24bit Over sampling
Load Impedance	600ohms or greater
S/N Ratio[1]	100dB (record or play)
THD+N[2]	0.002% (record or play)
Sample Rates	8 to 48kHz with 100Hz resolution
Frequency Response	20Hz to 20kHz +/-0.2dB

## DIGITAL INPUT/OUTPUT

Type	AES/EBU (EIAJ CP-340 Type I / IEC-958 Professional) S/PDIF (EIAJ CP-340 Type II / IEC-958 Consumer) (software selectable)
Connector	Mini26(SCSI-II type)
Sample Rates	32, 44.1 and 48kHz with sample rate converter on inputs

## SAMPLE RATE CLOCK

Internal	8 to 48kHz with 100Hz resolution
AES/EBU In	Dedicated AES/EBU clock input
Word In	External and Internal board-to-board link
Word Out	External and Internal board-to-board link

## SIGNAL PROCESSING

DSP	Texas Instruments TMS320C6711 @150MHz
Memory	8MB
Audio Formats	8 bit unsigned PCM 16bit signed PCM MPEG-1 Layer 2 MPEG-1 Layer 3(MP3) (MPEG Layer-3 audio coding technology licensed from Fraunhofer IIS and THOMSON multimedia)

## BREAKOUT CABLES (NOT INCLUDED)

Analog	CBL1004 : Mini 50 to Centronics 50 adapter. CBL1014: Centronics 50 to 2 in and 8 out XLR.
Digital	CBL1101: Mini 26 to Centronics 50 adapter. CBL1114: Centronics 50 to 1 in, 4 out XLR, 1 BNC in, 1 BNC out (Word Clock).

## GENERAL

Bus	Universal 32bit PCI (3.3V or 5V signaling)
Dimensions	PCI form factor - 10" x 3.9" x 0.6" (255mm x 100mm x 15mm)
Weight	8 oz (227g) max
Operating Temperature	0C to 70C
Power Requirements	+3V @ 1A, +5V @ 350mA, +12V @ 500mA, -12V @ 180mA (if no 3V is available then the board may be powered from a +5V only PCI bus, using jumper J9)

[2] - THD+N measured using a +14dBu 1kHz sine wave sampled at 48kHz and A weighting filter

[1] - S/N Ratio is the difference between a 1kHz +14dBu sine wave and digital zero using an A weighting filter

## 2. CONNECTORS

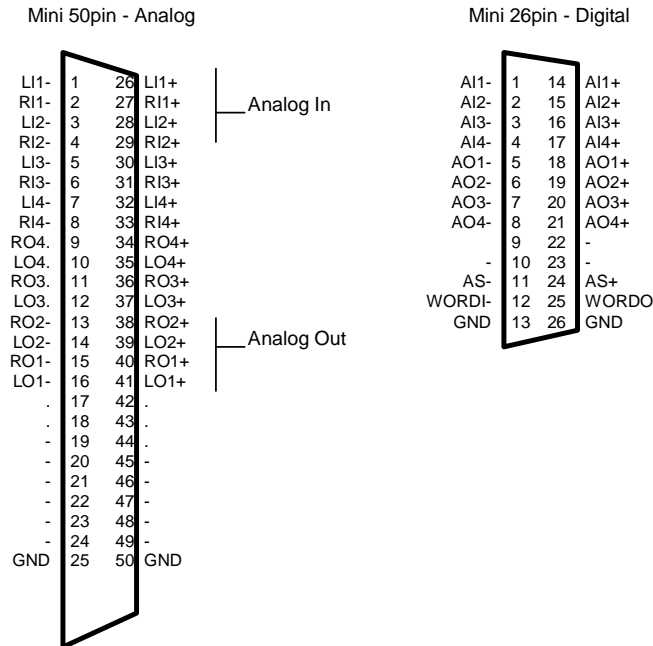

## 3. INSTALLATION

ASI6000 series adapters need a PCI slot that supplies 3.3V. Most PCs manufactured in 2000 or after will have this. If 3.3V is not supplied, then connect jumper J9. 3.3V will then be generated from an on-board regulator from the PCI's +5V.

## 4. AUDIO FORMATS

The ASI6244 supports the following audio formats:

Format	Rec/Play	HPI format	Windows format
8 bit unsigned PCM	P	HPI_FORMAT_PCM8_UNSIGNED	WAVE_FORMAT_PCM, wBitsPerSample=8
16 bit signed PCM	R/P	HPI_FORMAT_PCM16_SIGNED	WAVE_FORMAT_PCM, wBitsPerSample=16
32 bit signed PCM	R/P	HPI_FORMAT_PCM32_SIGNED	WAVE_FORMAT_PCM, wBitsPerSample=32
32 bit floating point PCM (+/-1.0)	R/P	HPI_FORMAT_PCM32_FLOAT	WAVE_FORMAT_IEEE_FLOAT
MPEG-1 Layer 2	R/P	HPI_FORMAT_MPEG_L2	WAVE_FORMAT_MPEG -fwHeadLayer=ACM_MPEG_LAYER2 -fwHeadMode=ACM_MPEG_SINGLECHANNEL, ACM_MPEG_DUALCHANNEL, ACM_MPEG_STEREO
MPEG-1 Layer 3	R/P	HPI_FORMAT_MPEG_L3	WAVE_FORMAT_MPEG -fwHeadLayer=ACM_MPEG_LAYER3 -fwHeadMode=ACM_MPEG_SINGLECHANNEL, ACM_MPEG_DUALCHANNEL, ACM_MPEG_STEREO  OR WAVE_FORMAT_MPEGLAYER3

## 5. DSP UTILISATION

The ASI6000 series of adapters have world-class audio signal processing capabilities. The ASI6000 algorithm complexity has increased at a faster rate than DSP processing power, resulting in a situation where not all available algorithms on an ASI6000 can run simultaneously.

The following tabulates processing “budgets” so that problem configurations can be identified before system design is completed. The following tables assign a utilization percentage for various operations. By summing up the utilizations for the target (worst case) configuration, one can determine whether audio processing will run without causing dropouts or breakup

### Adapter: ASI6244 Rev:F, Driver: 2.77

Adapter sample rate 32 kHz, Idle utilization 7%.

Operation	Record (utilization/ device)	Play (utilization/ device)
PCM16/24/32 @ 32 kHz	3%	3%
TimeScale (90%)	NA	9%
SamleRateConversion (110%)	NA	9%
SampleRate Conversion to/from 44.1kHz	9%	10%
SampleRate Conversion to/from 48kHz	9%	10%
MPEG layer-2, 256 kbps @ 32 kHz	17%	8%
MPEG layer-3, 256 kbps @ 32 kHz	40%	20%

Adapter sample rate 44.1 kHz, Idle utilization 13%.

Operation	Record (utilization/ device)	Play (utilization/ device)
PCM16/24/32 @ 44.1 kHz	3%	3%
TimeScale (90%)	NA	10%
SamleRateConversion (110%)	NA	11%
SampleRate Conversion to/from 32kHz	10%	10%
SampleRate Conversion to/from 48kHz	12%	13%
MPEG layer-2, 256 kbps @ 44.1 kHz	24%	10%
MPEG layer-3, 256 kbps @ 44.1 kHz	54%	24%

Adapter sample rate 48 kHz, Idle utilization 15%.

Operation	Record (utilization/ device)	Play (utilization/ device)
PCM16/24/32 @ 48 kHz	3%	3%
TimeScale (90%)	NA	11%
SamleRateConversion (110%)	NA	13%
SampleRate Conversion to/from 32kHz	10%	11%
SampleRate Conversion to/from 44.1kHz	12%	14%
MPEG layer-2, 256 kbps @ 48 kHz	26%	12%
MPEG layer-3, 256 kbps @ 48 kHz	60%	26%

The MIPs utilization calculation is more complicated on the ASI6244 because it has 2 DSPs on board. The “master” DSP contains all mixing, playback (waveOut devices) and records 3 & 4. The second DSP contain record devices 1 & 2. The second DSP can therefore be recording on Record 1 without affecting the MIPs utilization on the master DSP.

**[end]**