

### DESCRIPTION

The ASI6118 is a professional PCI audio adapter designed for use in the broadcast and entertainment markets, featuring 8 stereo or 16 mono outputs

It is based on the TMS320C6713 VLIW floating point DSP which runs at 225MHz and offers a peak of 1350MFLOPs.

A choice of 16, 24 and 32bit PCM, MPEG layer 2 and 3 (MP3) compression is available on all streams. A multi-rate digital mixer allows streams of different sample-rates and formats to be mixed together and sent to both analog and digital AES/EBU outputs

The ASI6118 provides two modes of operation – mono and stereo. In stereo mode, the board implements 8 stereo play streams, 1 stereo record stream, 8 stereo balanced analog, 6 AES/EBU outputs and 1 stereo balanced analog and AESEBU input.

In mono mode, 16 playback streams and 1 record stream can be mixed to 16 mono outputs.

Synchronization capabilities include an AES/EBU sync input and Word clock input and output.



### FEATURES

- Eight stereo/sixteen mono streams of MPEG Layer 3 (MP3), MPEG Layer2 or PCM playback into eight stereo/ sixteen mono outputs
- One mono/stereo stream of Layer3 (MP3), MPEG Layer2 or PCM record.
- MRX™ technology supports digital mixing of multiple stream formats and sample rates.
- TSX™ timescaling allows compression/expansion of play streams by up to +/-20% with no pitch shift.
- Eight-stereo/sixteen mono balanced analog and six digital play outputs. One balanced mono/stereo analog and digital input.
- 24bit analog-to-digital and digital-to-analog converters - 100dB SNR and 0.002% THD+N
- AES/EBU and S/PDIF digital audio input and output (software selectable) with sample rate converters on all inputs.
- AESEBU and Word clock Sync input allows adapter clock and AES/EBU outputs to be synchronized to external references
- Up to 8 cards in one system.
- Windows 95/98, Windows NT/2000 and Linux software drivers.

ASI6118 – Stereo mode

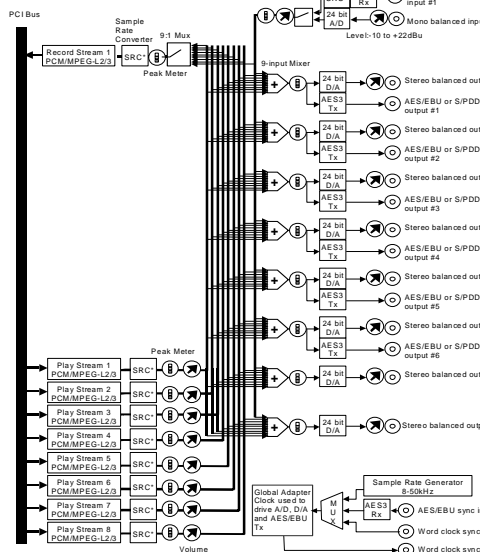

ASI6118 – 16 stream mode

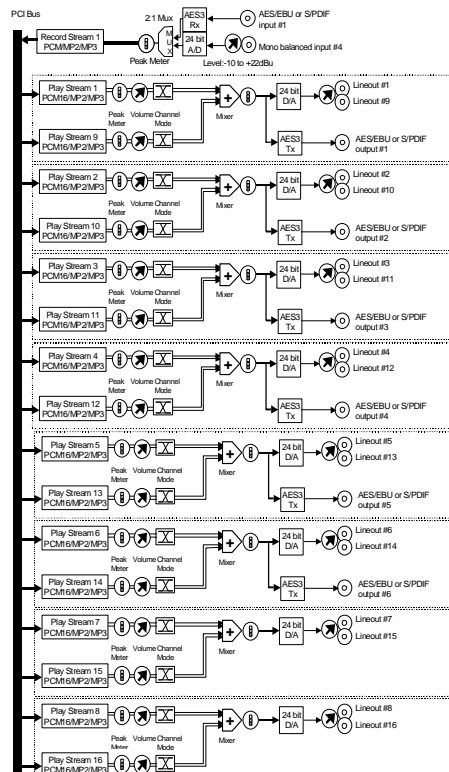

## 1. SPECIFICATIONS

### ANALOG INPUT/OUTPUT

Type	Balanced
Connector	Mini50 (SCSI-II type)
Input Level	-10 to +22dBu in 0.5dBu steps
Input Impedance	20K ohms
A/D converter	24bit Oversampling
Output Level	-10 to +22dBu in 0.5dBu steps
D/A converter	24bit Oversampling
Load Impedance	600ohms or greater
S/N Ratio <sup>[1]</sup>	100dB (record or play)
THD+N <sup>[2]</sup>	0.003% (record or play)
Frequency Response	20Hz to 20kHz +/-0.2dB

### DIGITAL INPUT/OUTPUT

Type	AES/EBU (EIAJ CP-340 Type I / IEC-958 Professional) S/PDIF (EIAJ CP-340 Type II / IEC-958 Consumer) (software selectable)
Connector	Mini26(SCSI-II type)
Sample Rates	32, 44.1 and 48kHz with sample rate converter on inputs

### SAMPLE RATE CLOCK

Internal	8 to 48kHz with 100Hz resolution
AES/EBU In	Dedicated AES/EBU clock input
Word In	External and Internal board-to-board link
Word Out	External and Internal board-to-board link

### SIGNAL PROCESSING

DSP	Texas Instruments TMS320C6711 @150MHz
Memory	8MB
Audio Formats	8 bit unsigned PCM 16bit signed PCM MPEG-1 Layer 2 MPEG-1 Layer 3 (MP3) (MPEG Layer-3 audio coding technology licensed from Fraunhofer IIS and THOMSON multimedia)

### BREAKOUT CABLES (NOT INCLUDED)

Analog	CBL1004 : Mini 50 to Centronics 50 adapter. CBL1018: Centronics 50 to 2 in and 16 out XLR.
Digital	CBL1101: Mini 26 to Centronics 50 adapter. CBL1118: Centronics 50 to 1 in, 8 out XLR, 1 BNC in, 1 BNC out (Word Clock).

### GENERAL

Bus	Universal 32bit PCI (3.3V or 5V signaling)
Dimensions	PCI form factor - 10" x 3.9" x 0.6" (255mm x 100mm x 15mm)
Weight	8 oz (227g) max
Operating Temperature	0C to 70C
Power Requirements	+3V @ 1A, +5V @ 300mA, +12V @ 600mA, -12V @ 300mA (if 3V is not available then the board may be powered from a +5V only PCI bus, using Jumper J9)

[2] - THD+N measured using a +20dBu 1kHz sinewave sampled at 48kHz and A weighting filter

[1] - S/N Ratio is the difference between a 1kHz +20dBu sinewave and digital zero using an A weighting filter

## INSTALLATION

ASI6000 series adapters need a PCI slot that supplies 3.3V. Most PCs manufactured in 2000 or after will have this. If 3.3V is not supplied, then connect jumper J9. 3.3V will then be generated from an on-board regulator from the PCI's +5V.

## 2. CONNECTORS

Mini 50pin - Analog

LI1-	1	26	LI1+
RI1-	2	27	RI1+
-	3	28	
-	4	29	
-	5	30	
-	6	31	
-	7	32	
-	8	33	
RO4-	9	34	RO4+
LO4-	10	35	LO4+
RO3-	11	36	RO3+
LO3-	12	37	LO3+
RO2-	13	38	RO2+
LO2-	14	39	LO2+
RO1-	15	40	RO1+
LO1-	16	41	LO1+
RO5-	17	42	RO5+
LO5-	18	43	LO5+
RO6-	19	44	RO6+
LO6-	20	45	LO6+
RO7-	21	46	RO7+
LO7-	22	47	LO7+
RO8-	23	48	RO8+
LO8-	24	49	LO8+
GND	25	50	GND

Analog In

Analog Out

Mini 26pin - Digital

AI1-	1	14	AI1+	AES/EBU In
-	2	15		
-	3	16		
-	4	17		
AO1-	5	18	AO1+	
AO2-	6	19	AO2+	
AO3-	7	20	AO3+	AES/EBU Out
AO4-	8	21	AO4+	
AO5-	9	22	AO5+	
AO6-	10	23	AO6+	
AS-	11	24	AS+	Sync In
WORDI-	12	25	WORDO	
GND	13	26	GND	

[end]