

ASI4344

DIGITAL AUDIO ADAPTER

mp3
decode
ISO/MPEG-1 LAYER II

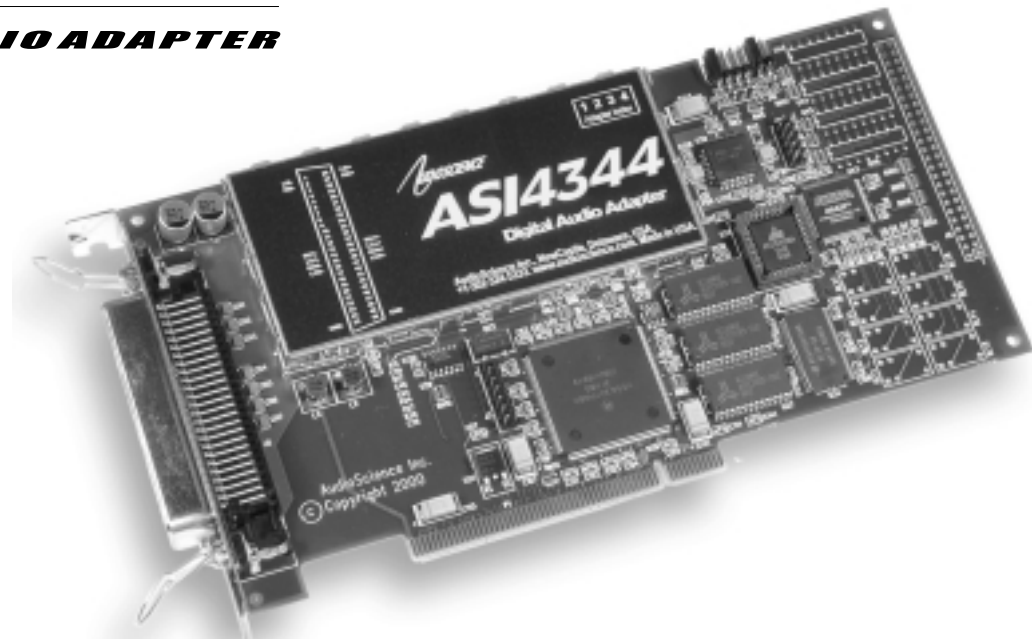

FEATURES

Four stereo streams of playback and three balanced stereo inputs mixed to four balanced stereo outputs.

One stereo stream of record selectable from three stereo feedthrough inputs.

High speed PCI bus interface.

Formats include MP3, MPEG-1 Layer 2 and 16bit PCM.

Programmable global samplerate of 8 to 50kHz.

Standard 50pin "Centronics" type connector.

Velocity control of stream playback enables true "reel-rocking" in audio editor applications.

20bit oversampling analog-to-digital and digital-to-analog converters. >90dB S/N and <0.005% THD+N.

8Mbyte DRAM for on-board buffering

Automatic volume fade implemented by DSP for cross-fade and mixing effects.

Upto four cards in one system.

DOS, Windows 98, Windows NT/2000 and Linux software drivers available.

Designed and manufactured in the USA.

The ASI4344 provides native MP3 playback for PC-based broadcast audio. Record, play and mix up to seven stereo streams including three feedthrough channels.

The ASI4344 provides tremendous value in a feature-laden digital audio adapter with powerful on-board MP3 playback capability. The ASI4344 features four stereo playback streams mixable to four stereo balanced analog outputs. In addition three balanced inputs are routable to both the record stream and two of the balanced outputs. With the power of the advanced DSP chips on the ASI4344, you can record soundbites while playing program material, or switch from satellite feed to local programming and back without glitches. The powerful MP3 audio

format retains CD quality broadcasting while requiring as little as one tenth of linear PCM storage requirements. Playback stream velocity control enables true "reel-rocking" type scrubbing in digital audio editor applications. Other advanced features like the Channel Mode control, let you easily configure a mono signal for a stereo feed. Listen closely. With 20-bit oversampling A/D and D/A converters, you won't hear higher quality audio in any comparably priced soundcard. If you want more digital audio functionality from your broadcast PC, the ASI4344 is for you.

ASI4344

DIGITAL AUDIO ADAPTER

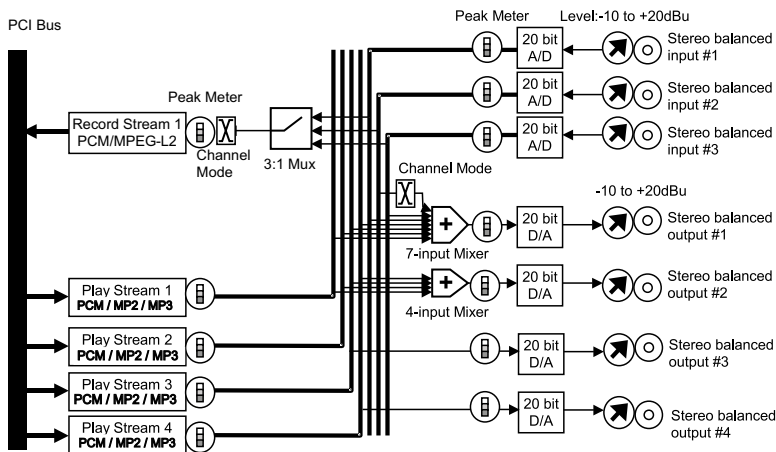

Channel-Mode Control



Modes of operation

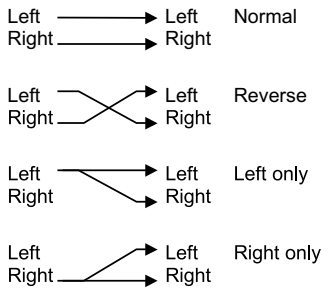

50pin Centronics Connector

LI0-	1	26	LI0+
RI0-	2	27	RI0+
LI1-	3	28	LI1+
RI1-	4	29	RI1+
LI2-	5	30	LI2+
RI2-	6	31	RI2+
	7	32	
	8	33	
RO3-	9	34	RO3+
LO3-	10	35	LO3+
RO2-	11	36	RO2+
LO2-	12	37	LO2+
RO1-	13	38	RO1+
LO1-	14	39	LO1+
RO0-	15	40	RO0+
LO0-	16	41	LO0+
	17	42	
	18	43	
	19	44	
	20	45	
	21	46	
	22	47	
	23	48	
	24	49	
GND	25	50	GND

SPECIFICATIONS

ANALOG INPUTS

Type	Balanced
Connector	50pin Centronics
Level	-10 to +20dBu in 0.5dBu steps
Impedance	20K ohms
A/D converter	20bit, 128X Oversampling
S/N Ratio ¹	90dB minimum
THD+N ²	86dB minimum
Sample Rates	8 to 48kHz with 100Hz resolution
Frequency Response	20Hz to 20kHz +/-0.5dB

ANALOG OUTPUTS

Type	Balanced
Connector	50pin Centronics
Level	-10 to +20dBu in 0.5dBu steps
Load Impedance	600ohms or greater
D/A converter	20bit
S/N Ratio ¹	90dB minimum
THD+N ²	86dB minimum
Sample Rates	8 to 48kHz with 100Hz resolution
Frequency Response	20Hz to 20kHz +/-0.5dB

SIGNAL PROCESSING

DSP	100MHz Motorola DSP56301
Audio Formats	8 bit unsigned PCM 16bit signed PCM MPEG-1 Layer 2 MPEG-1 Layer 3 (MP3)

GENERAL

Dimensions	PCI form factor - 9" x 4.5" x 0.6" (230mm x 115mm x 15mm)
Weight	10 oz (284g) max
Operating Temperature	0C to 70C
Power Requirements	+5V @ 1.2mA +12V @ 300mA -12V @ 300mA

[1] - S/N Ratio is the difference between a 1kHz +14dBu sinewave and digital zero using an A weighting filter
[2] - THD+N measured using a +14dBu 1kHz sinewave sampled at 48kHz and A weighting filter

TESTED TO COMPLY WITH

