

ASI4312

DIGITAL AUDIO ADAPTER

The AudioScience ASI4300 family of digital audio adapters enable cost-effective multi-stream recording and reproduction of MPEG Layer 2 digital audio on the PC platform. Utilising the 32bit PCI bus and the latest generation of 24bit DSPs from Motorola, these cards were designed to deliver the highest performance available to the broadcast industry.

FEATURES

- Four stereo streams of playback.
- One stereo stream of record.
- Formats include MPEG Layer 2 and 16bit PCM.
- Programmable global samplerate of 8 to 50kHz in 100Hz steps
- Two balanced stereo analog play outputs. One balanced stereo analog input.
- Standard 50pin "Centronics" type connector for easy wiring.
- 20bit oversampling analog-to-digital and digital-to-analog converters. >90dB S/N and <0.005% THD+N.
- High speed 32bit PCI bus interface.
- 8MByte DRAM for on-board buffering.
- Programmable non-volatile memory for OEM data storage.
- Automatic volume fade implemented by DSP for cross-fade and mixing effects.
- Upto four cards in one system.
- MPEG bitstreams contain visualisation information and are BWF, Digigram and Antex compatible.
- DOS, Windows 95/98, Windows NT and Linux software drivers available.
- Designed and manufactured in the USA

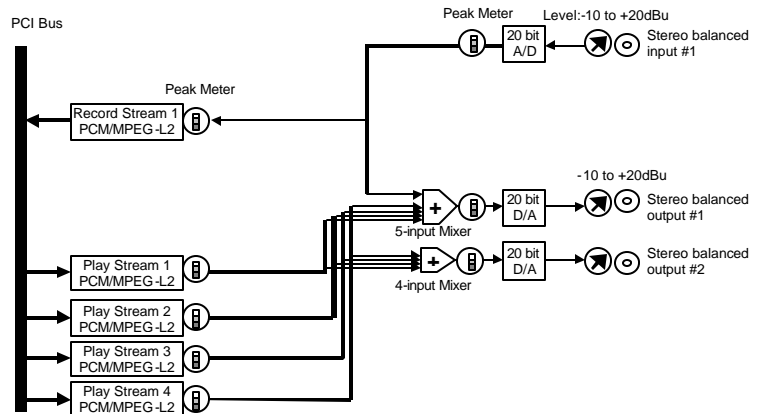

50pin Centronics Connector

