

ASI4111

DIGITAL AUDIO ADAPTER

The AudioScience ASI4100 family of digital audio adapters enable multi-stream recording and reproduction of MPEG Layer 2 digital audio on the PC platform. Utilising the 32bit PCI bus and the latest generation of 24bit DSPs from Motorola, these cards were designed to deliver the highest performance available to the broadcast industry.

FEATURES

- Two streams of MPEG Layer 2 playback and one stream of MPEG Layer 2 record simultaneously.
- All streams have independent sample rate and compression format.
- Professional balanced audio input and output
- AES/EBU and S/PDIF digital audio input and output
- 20bit analog-to-digital and digital-to-analog converters
- High speed PCI bus interface
- 2MB DRAM for on-board buffering.
- Programmable non-volatile memory for OEM data storage
- Automatic volume fade implemented by DSP for cross-fade and mixing effects
- Upto four cards in one system
- MPEG bitstreams contain visualisation information and are BWF, Digigram and Antex compatible.
- DOS, Windows 95 and Windows NT software drivers available
- Designed and manufactured in the USA

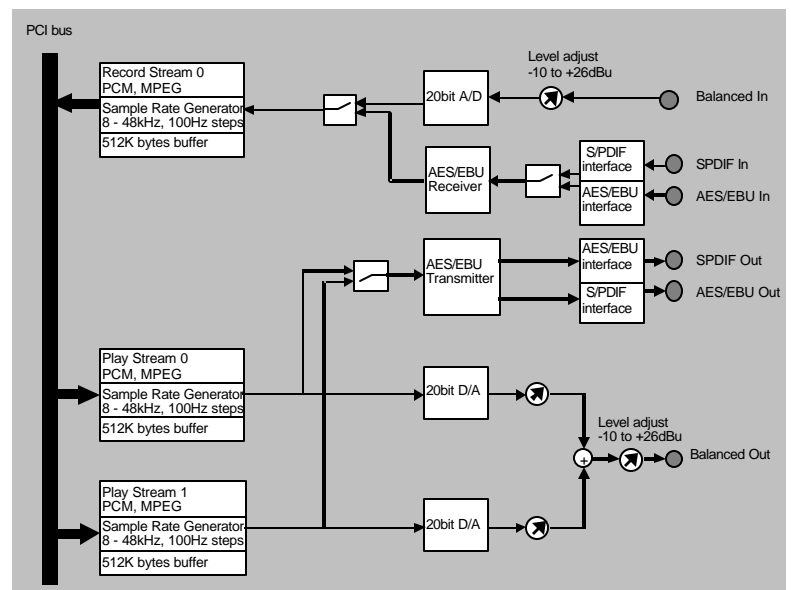

SPECIFICATIONS

ANALOG INPUT

Type	Balanced
Connector	Female DB-9
Level	-10 to +26dBu in 0.5dBu steps
Impedance	20K ohms
A/D converter	20bit, 128X Oversampling
S/N Ratio ^[1]	92dB minimum
THD+N ^[2]	88dB minimum
Sample Rates	8 to 50kHz with 100Hz resolution
Frequency Response	20Hz to 20kHz +/-1dB

ANALOG OUTPUTS

Type	Balanced
Connector	Female DB-9
Level	-10 to +24dBu in 0.5dBu steps
Load Impedance	600ohms or greater
D/A converter	20bit
S/N Ratio ^[1]	92dB minimum
THD+N ^[2]	90dB minimum
Sample Rates	8 to 50kHz with 100Hz resolution
Frequency Response	20Hz to 20kHz +/-1dB

DIGITAL INPUT

Type	AES/EBU (EIAJ CP-340 TypeI / IEC-958 Professional) S/PDIF (EIAJ CP-340 TypeII / IEC-958 Consumer)
Connector	Male DB-9
Sample Rates	32, 44.1 and 48kHz

DIGITAL OUTPUT

Type	AES/EBU (EIAJ CP-340 TypeI / IEC-958 Professional) S/PDIF (EIAJ CP-340 TypeII / IEC-958 Consumer)
Connector	Male DB-9
Sample Rates	32, 44.1 and 48kHz

SIGNAL PROCESSING

DSP	80MHz Motorola DSP56301
Audio Formats	8 bit unsigned PCM 16bit signed PCM MPEG-1 Layer 1 (Decode only) MPEG-1 Layer 2

GENERAL

Dimensions	PCI form factor - 8" x 4.5" x 0.6" (200mm x 115mm x 15mm)
Weight	16 oz (454g) max
Operating Temperature	0C to 70C
Power Requirements	+5V @ TBDmA +12V @ TBDmA -12V @ TBDmA

CONNECTOR PINOUTS

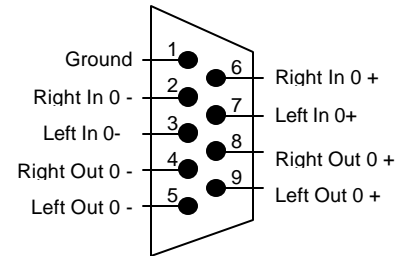

Analog 1 - 9pin DB female

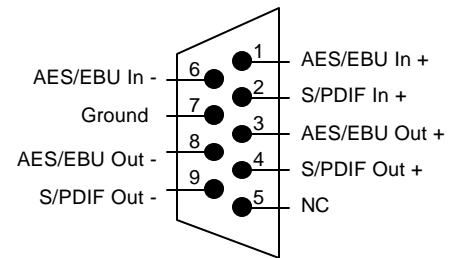

Digital - 9pin DB male

[1] - S/N Ratio is the difference between a 1kHz +14dBu sinewave and digital zero using an A weighting filter

[2] - THD+N measured using a +14dBu 1kHz sinewave sampled at 48kHz and A weighting filter