

1 DESCRIPTION

The ASI1433 is an analog output module intended for use in the ASI2416 Modular CobraNet™ Interface. It contains eight outputs and operates at a 48kHz sample rate.

Up to four ASI1433 modules may be used in one ASI2416. AudioScience's CobraNet implementation, based on the CobraNet chip used, allows for up to 16 outputs, out of a possible 32, to be used at any given time.

A unique feature of the ASI1433 is its interchangeable I/O connector. A choice of 50pin Centronics (ASI1491), StudioHub+™ (ASI1492) or Terminal block (ASI1493) allows the module to adapt to a wide variety of interconnection schemes with minimal custom wiring.

2 FEATURES

- Eight outputs
- 24bit digital-to-analog converters: 105dB SNR and 0.0015% THD+N
- -10 to +24dBu software controlled output level
- Interchangeable Module Connectors with choice of Terminal Block, StudioHub+™ RJ-45, or 50pin Centronics connector
- Up to four modules can be used in one ASI2416

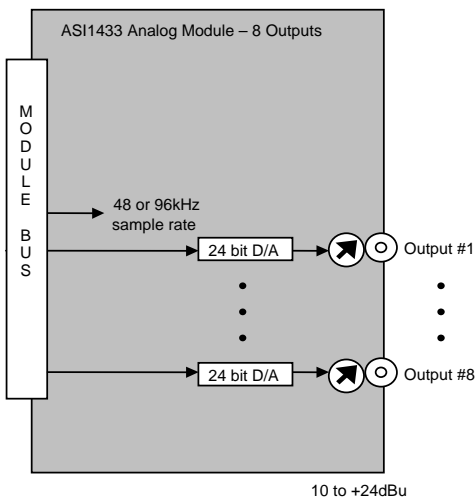

ASI1433



ASI1491
50 pin Centronics



ASI1492
StudioHub



ASI1493
Terminal Block

3 SPECIFICATIONS

ANALOG OUTPUT

Type	Balanced
Output Level	-10 to +24dBu in 1dBu steps
D/A converter	24bit Over sampling
Load Impedance	600ohms or greater
S/N Ratio[1]	>105dB (record or play)
THD+N[2]	<0.0015% (record or play)
Sample Rates	48kHz
Frequency Response	20Hz to 20kHz +0.1/-0.30dB

SAMPLE RATE CLOCK

Internal	48 kHz
----------	--------

CONNECTOR MODULES

ASI1491	50 pin Centronics
ASI1492	StudioHub compatible RJ-45 jacks.
ASI1493	5 position 3.81mm pluggable terminal block (8 per module)

GENERAL

Bus	AudioScience ASI2400 series module bus
Dimensions	(Without Module Connector) 5.5" x 3.25" x 0.6" (140mm x 83mm x 15mm)
Weight	8 oz (227g) max
Operating Temperature	0C to 70C
Power Requirements	+5V @ 500mA

[2] - THD+N measured using a +20dBu 1kHz sine wave sampled at 48kHz, 20-20kHz b/w and A weighting filter
 [1] - S/N Ratio is the difference between a 1kHz +20dBu sine wave and digital zero using an A weighting filter and 20-20kHz b/w



4 REVISIONS

Date	Description
27 June 2009	Elaborated first page, second paragraph.
	Updated format, including adding a REVISIONS section.
03 December 2009	Section 3: Adjust frequency response to +0.1/-0.3dB.

5 MODULE CONNECTORS

5.1 ASI1491 50pin Centronics

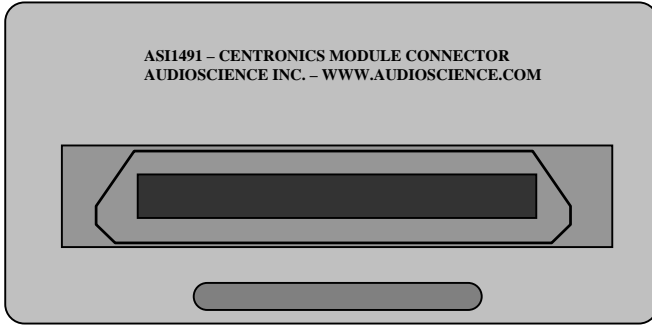

The ASI1491 Module Connector provides a 50pin Centronics connector (also referred to as a 50pin SCSI connector). AudioScience's CBL1046 XLR breakout cable can be used with this connector.

The table to the right shows the pinouts when used with the ASI1433 Analog Module.

50pin Centronics Connections			
Signal	Pin #	Pin #	Signal
	1	26	
	2	27	
	3	28	
	4	29	
	5	30	
	6	31	
	7	32	
	8	33	
Output 8 -	9	34	Output 8 +
Output 7 -	10	35	Output 7 +
Output 6 -	11	36	Output 6 +
Output 5 -	12	37	Output 5 +
Output 4 -	13	38	Output 4 +
Output 3 -	14	39	Output 3 +
Output 2 -	15	40	Output 2 +
Output 1 -	16	41	Output 1 +
	17	42	
	18	43	
	19	44	
	20	45	
	21	46	
	22	47	
	23	48	
	24	49	
GND	25	50	GND

5.1.1 CBL1046 – 8 Analog XLR In Cable



CBL1046, purchased separately, can be used with the ASI1491 50pin Centronics connector and the ASI1433 analog module. It is a 50pin to 8 out XLR, balanced analog cable.

5.2 ASI1492 StudioHub+ (RJ45)

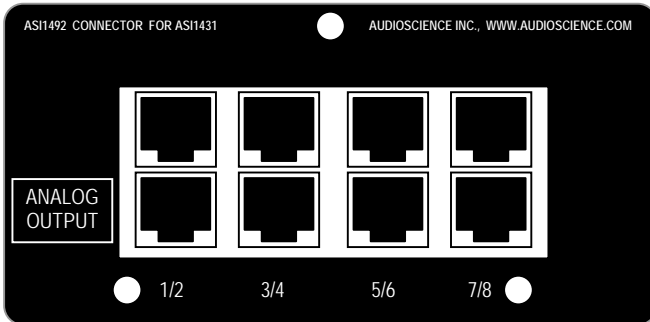

StudioHub (RJ45) Connections		
Pin	Function	Color Code
Shield	Ground	
1	Channel 1/3/5/7 +	Green/White
2	Channel 1/3/5/7 -	Green
3	Channel 2/4/6/8 +	Orange/White
4		
5		
6	Channel 2/4/6/8 -	Orange
7		
8		

The ASI1492 StudioHub Module Connector provides pairs of outputs on an RJ-45 type jack compatible with the Radio Systems StudioHub standard. This allows the balanced analog signal to be transmitted using shielded twisted pair (STP) cable.

The RJ45 connections are shown in the table to the right. Only the bottom output jacks are used.

For more information on the StudioHub standard, see www.studiohub.com.

5.3 ASI1493 Terminal Block

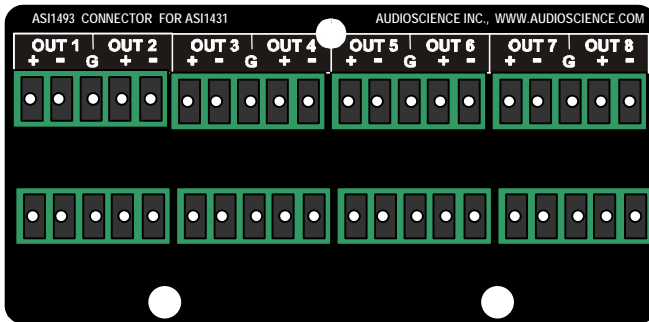

The ASI1493 Terminal Block Connector provides 3.81mm pluggable terminal blocks.

When used with the ASI1433 module, only the top output terminals are used, as labeled in the diagram to the left.

<end>