

1. DESCRIPTION

The BOB1025 is a StudioHub™ breakout box for AudioScience audio adapters. It can be operated as either an analog breakout (4 stereo in and 8 stereo out) or AES/EBU digital breakout (4 stereo in, 6 stereo out and sync in/out).

All I/O is balanced on RJ-45 connectors using the StudioHub protocol. Connections to the audio adapter are via a 50pin high-density SCSI type connector for analog and a 26pin high-density connector for digital (AES/EBU).

The BOB1025 is 1RU; 19" W x 5.5" D x 1.75" H (482.6 mm W x mm 139.7 D x NN mm 44.5 H).

AudioScience cards that are supported include the ASI5000 series, ASI6000 series and the ASI4300 series.



NOTE: The BOB1025 Can be operated in Analog OR Digital (AES/EBU) mode, but not both at the same time

2. CONFIGURATIONS

2.1 Analog Mode

In this mode, one BOB1025 supports 4 stereo inputs and 8 stereo outputs. Cable CBL1006 is needed when connecting to an ASI6000 series or ASI5000 series card and CBL1005 when connecting to an ASI4300 series card.

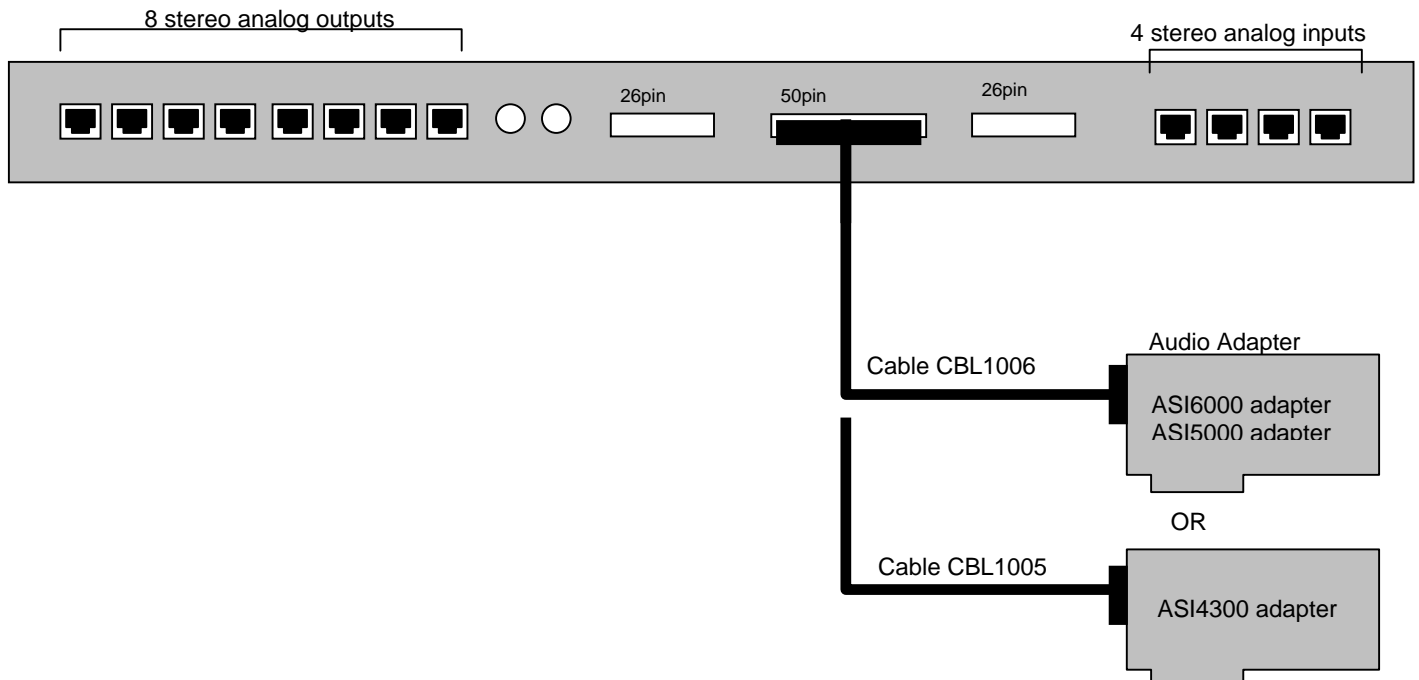

2.3 Digital Mode

In this mode, one BOB1025 supports 4 AES/EBU stereo inputs, 6 AES/EBU stereo outputs, AES/EBU sync in and word clock in. Cable CBL1102 is needed when connecting to an ASI5000 or 6000 series card.

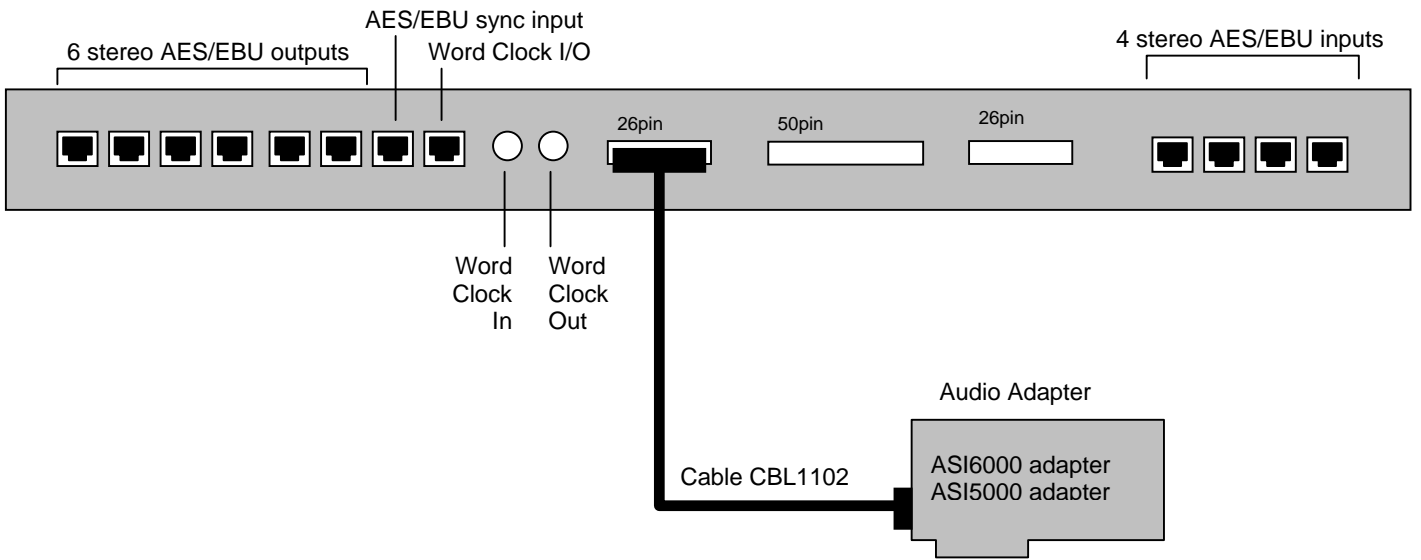

NOTE: On ASI6518 or ASI6618 sound cards, AES inputs 3 and 4 can be assigned as outputs 7 and 8. This allows one BOB1025 to be used; it will then have 8 AES/EBU 'outputs'. Please refer to the ASI6518/ASI6618 datasheet for further information on how to set this up.

<end>